

LEAN

4.0 Lean

XMach
Smart Machines

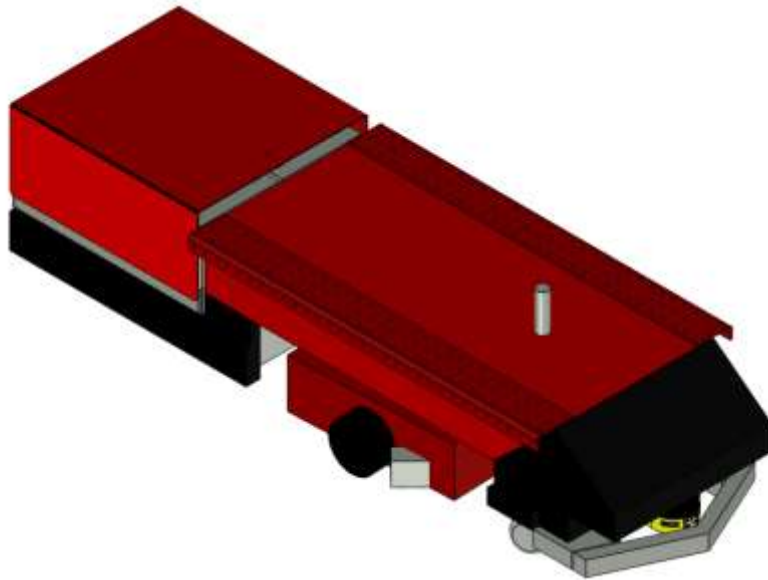

Vol. VI

We Build Lean

4.0 Lean

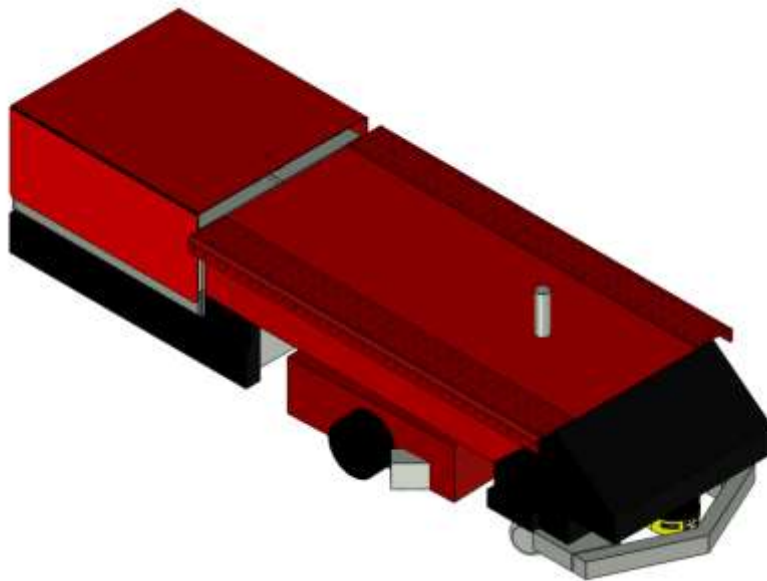

AGV



Trolley4AGV

Pick2Light 



Andon

Save &
Control



AGV

| AGV | AGV | AGV | AGV

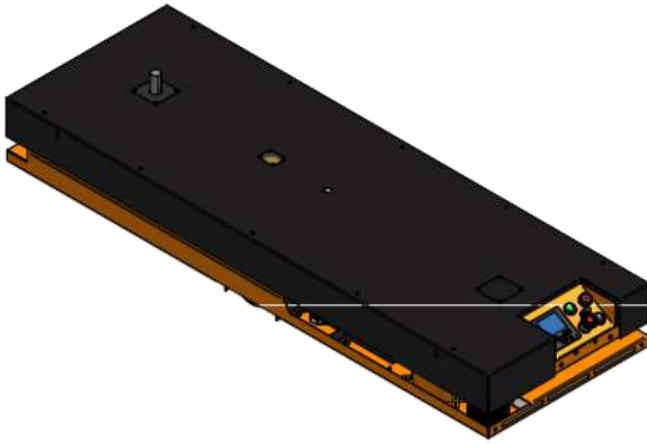

AGV-01

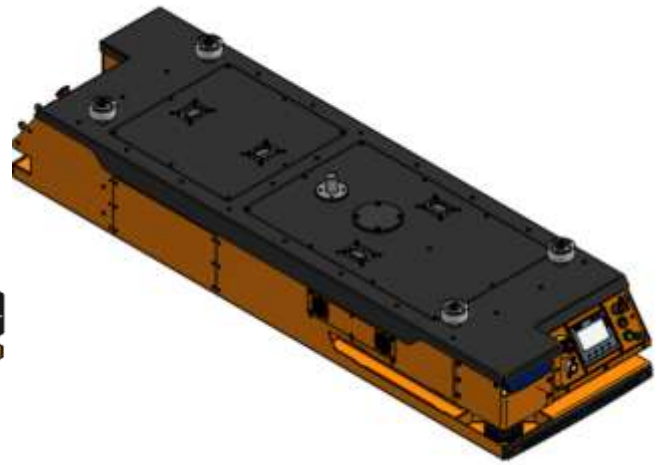

AGV-02

AGV					
Reference Referência Articolo Referencia Référence	Traction capacity Capacidade de tração/Capacità di trazione/Capacidad de tracción/Capacité de traction	Speed Velocidade/velocità/velocidad/vitesse	Guidance Type Tipode guiamento/Tipo di guida/Tipo de orientación/Type de guidage	Description Descrição/Descrizione Descripción/Description	Autonomy Autonomia/Autonomia/Autonomía/Autonomie
AGV-01	600N	From 0,05 to 1,5m/s	Magnetic Tape	Length: 1500mm Height: 190mm Width: 500mm	8h
AGV-02			Natural	Length: 1850mm Height: 300mm Width: 550mm	

AGV Accessories

| AGV Acessórios | AGV Accessori | AGV Accesorios | AGV Accessoires

AGV Magnetic Tracking tape						
Reference Referência Articolo Referencia Référence	Polarity Polaridade Polarità Polaridad Polarité	Adhesive Adesivo Adesivo Adhesivo	Application area Area de aplicação Area di applicazione Área de aplicaci3n Champ d'application	Width Largura Larghezza Anchura Largeur	Thickness Espessura Spessore Grosor Épaisseur	Product Produto Prodotto Producto Produit
AGV-MTN	North Norte Nord Norte Nord	Acrylate Acrílico Acrílico Acrylique	Inside interior Interno Interior à l'intérieur	25 mm	1,2 mm	
AGV-MTS	South Sul Sud Sur Sud					

Ex.:



AGV Optical Tracking tape						
Reference Referência Articolo Referencia Référence	Material Material Materiale Material Matériel	Adhesive Adesivo Adesivo Adhesivo Adhésif	Application area Area de aplicação Area di applicazione Área de aplicaci3n Champ d'application	Width Largura Larghezza Anchura Largeur	Thickness Espessura Spessore Grosor Épaisseur	Product Produto Prodotto Producto Produit
AGV-OT	PVC	Acrylate Acrílico Acrílico Acrylique	Inside interior Interno Interior à l'intérieur	25 mm	0,5 mm	

Ex.:



AGV Accessories

| AGV Acessórios | AGV Accessori | AGV Accesorios | AGV Accessoires

CUSTOMIZED SOLUTION

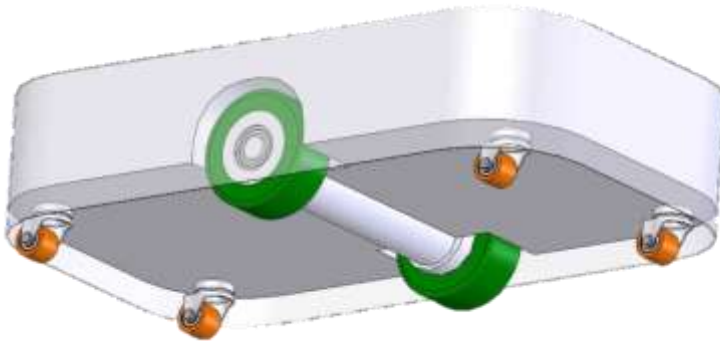

AGV Casters

Type Tipo/Tipo Tipo/Type	Reference Referência/ Articolo/ Referencia/ Référence	Brake type Tipo de travão Tipo di freno Tipo de freno Type de frein								
	RO2-150FFR	-	151	71,7	ø50	40	A= Polyurethane B= Aluminium	Ball Esferas /Sfera/ Esfera / Sphère	A=45 B=45	150
	RO2-150FFR	-	151	71,5	ø50	40	A= Polyurethane B= Aluminium	Ball Esferas /Sfera/ Esfera / Sphère	ø10	150



Trolley AGV Wagon → AGV Compatible

| Carrinho AGV Wagon - Compatível com AGV | Carrello AGV Wagon - Compatibile con AGV

| Trolley AGV Wagon - Compatible con AGV | Chariot AGV Wagon .- Compatible AGV

CUSTOMIZED SOLUTION

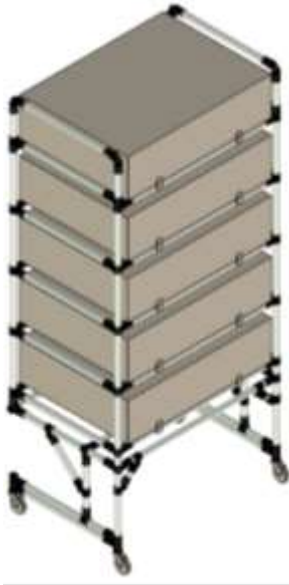

4LEAN



OMRON



4LEAN



MIR
A BETTER WAY



Trolley4AGV

Trolley AGV Wagon → AGV Compatible

| Carrinho AGV Wagon - Compatível com AGV | Carrello AGV Wagon - Compatibile con AGV

| Trolley AGV Wagon - Compatible con AGV | Chariot AGV Wagon - Compatible AGV



ASTI



CUSTOMIZED SOLUTION

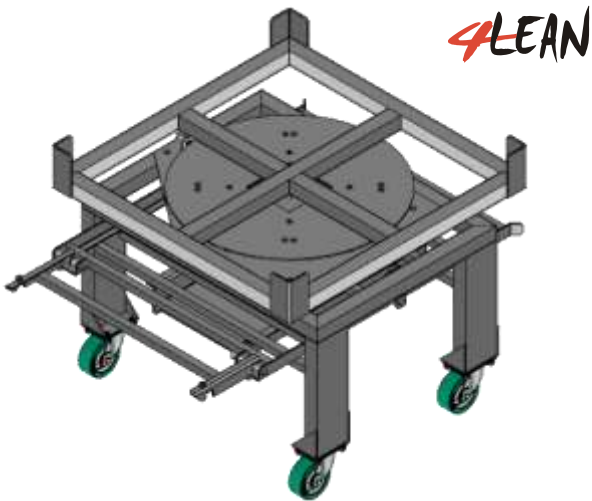

KIVIN

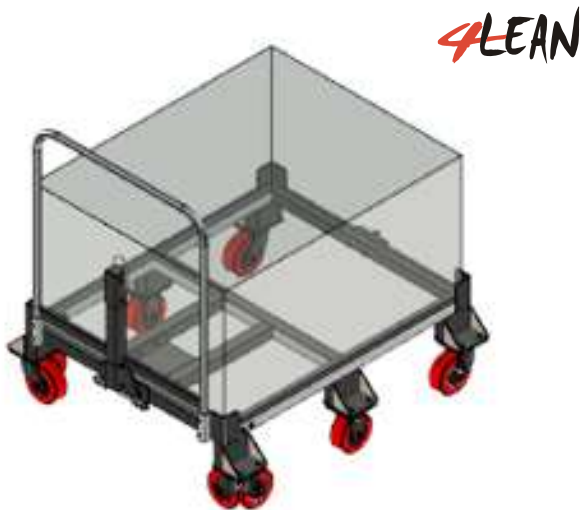

activespace

activeONE



Trolley4AGV

Trolley AGV Wagon → AGV Compatible

| Carrinho AGV Wagon - Compatível com AGV | Carrello AGV Wagon - Compatibile con AGV

| Trolley AGV Wagon - Compatible con AGV | Chariot AGV Wagon .- Compatible AGV

CUSTOMIZED SOLUTION



synergisight
SMART LOGISTICS



IMEQUISA
GROUP



Trolley4AGV

Trolley AGV Wagon → AGV Compatible

| Carrinho AGV Wagon - Compatível com AGV | Carrello AGV Wagon - Compatibile con AGV

| Trolley AGV Wagon - Compatible con AGV | Chariot AGV Wagon .- Compatible AGV

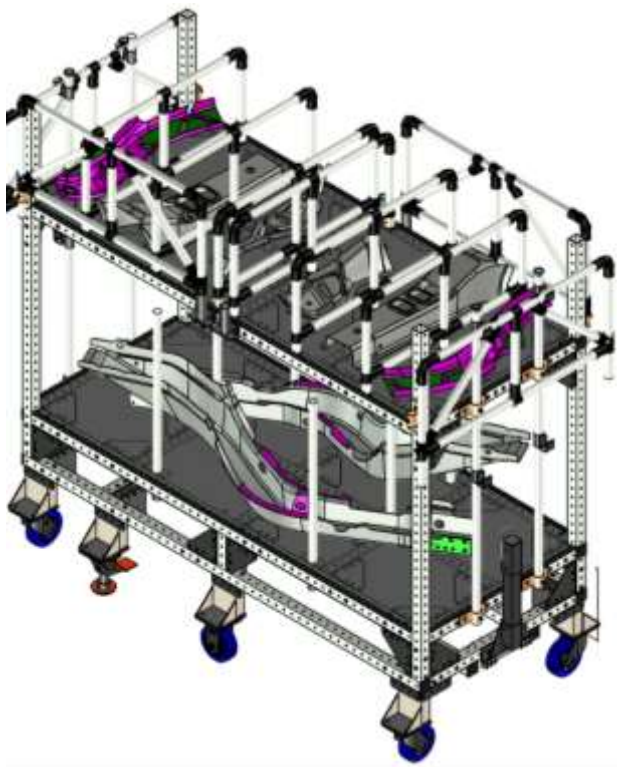

CUSTOMIZED SOLUTION



Send us your
AGV
requirements



We develop
your Wagon

Chassis for AGV

| Chassis para AGV | Telaio per AGV | Chasis para AGV | Châssis pour AGV

**CUSTOMIZED
SOLUTION**

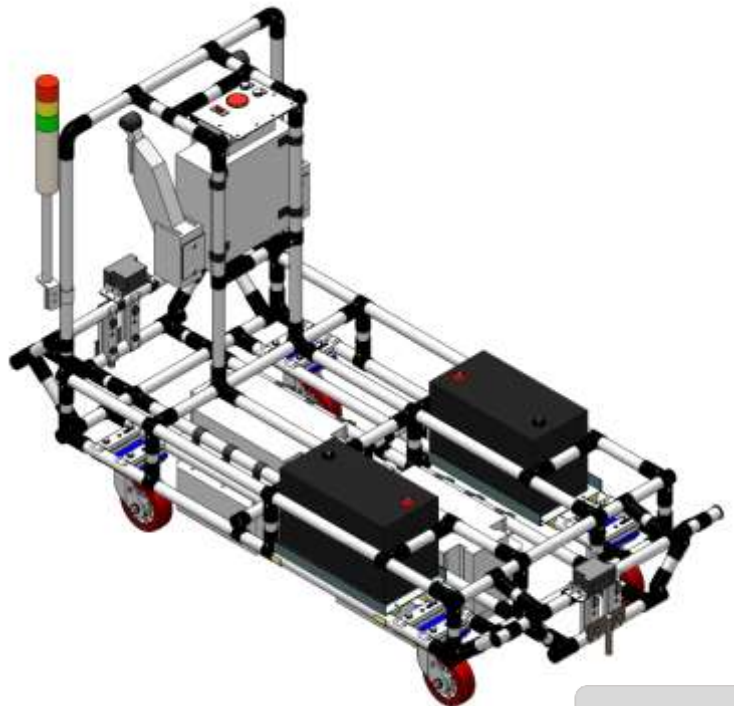
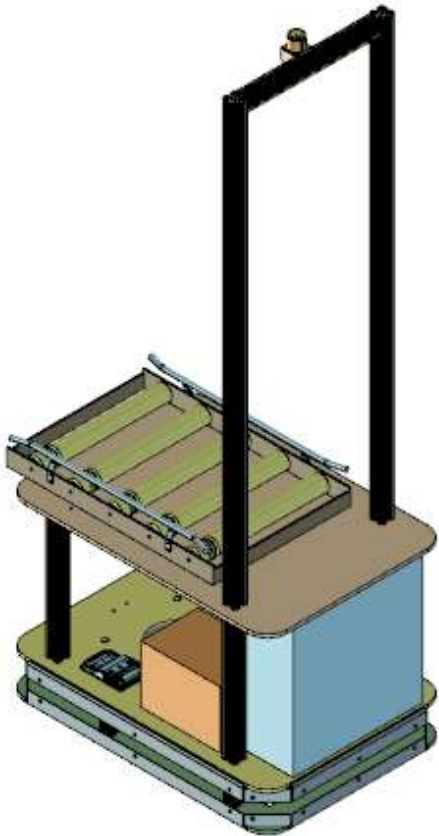
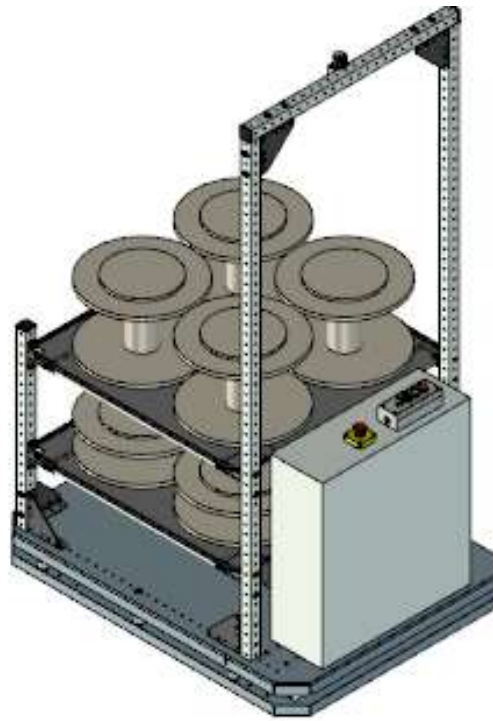

Trolley4AGV

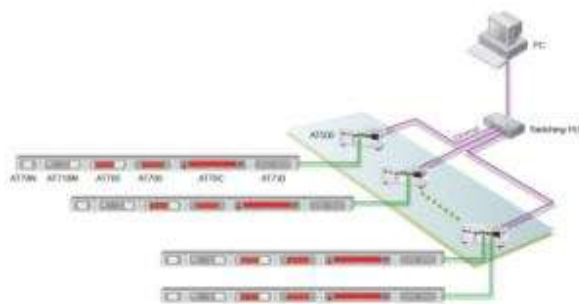

Pick-to-Light – Controllers

| Pick-to-Light - Controladores | Pick-to-Light - Controllori | Pick-to-Light – Controladores |
| Pick-to-Light – Contrôleurs|







Pick-to-Light – Controllers

Pick-to-Light – Controladores / Pick-to-Light – Controllori / Pick-to-Light – Controladores / Pick-to-Light – Contrôleurs

Reference Referência Articolo Referencia Référence	Product Produto/ Prodotto / Producto / Produit	Description Descrição/Descrizione Descripción/Description	Characteristics Características / Caratteristiche / Características / Caracteristiques
PTL500 TCP/IP		250mm(L) x 130mm(C) x 100mm(A) - TCP/IP Controller	<ul style="list-style-type: none"> • A Maximum of 120 light module can be connected / Um máximo de 120 módulo de luz pode ser conectado / È possibile collegare un massimo di 120 moduli luce / Un máximo de 120 módulo de luz se puede conectar / Un maximum de 120 module d'éclairage peut être connecté • 10/100 Mbps Ethernet TCP/IP Protocol
PTL400 TCP/IP		Compact TCP/IP Controller	<ul style="list-style-type: none"> • A Maximum of 30 light module can be connected / Um máximo de 30 módulo de luz pode ser conectado / È possibile collegare un massimo di 30 moduli luce / Un máximo de 30 módulo de luz se puede conectar / Un maximum de 30 module d'éclairage peut être connecté • 10/100 Mbps Ethernet TCP/IP Protocol

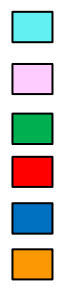
Pick-to-Light – Modules

Pick-to-Light – Módulos / Pick-to-Light – Moduli / Pick-to-Light – Módulos / Pick-to-Light – Modules

Reference Referência Articolo Referencia Référence	Product Produto/ Prodotto / Producto / Produit	Description Descrição/Descrizione Descripción/Description	Characteristics Características / Caratteristiche / Características / Caracteristiques	Colours Cores/Colore Colores/Couleur
PTL705		148mm(L) x 46mm(W) x 30mm(H) pick-to-light module	<ul style="list-style-type: none"> • 5-digit display / Display com 5 dígitos / Display a 5 cifre / Pantalla de 5 dígitos / Affichage 5 chiffres • 2 up/down function keys / 2 teclas de função para cima / baixo / 2 tasti di funzione alto / basso / 2 arriba / abajo teclas de función / 2 touches de fonction haut / bas 	
PTL703		148mm(L) x 46mm(W) x 30mm(H) pick-to-light module	<ul style="list-style-type: none"> • 3-digit display / Display com 3 dígitos / Display a 3 cifre / Pantalla de 3 dígitos / Affichage 3 chiffres • 2 up/down function keys / 2 teclas de função para cima / baixo / 2 tasti di funzione alto / basso / 2 arriba / abajo teclas de función / 2 touches de fonction haut / bas 	
PTL703A		148mm(L) x 46mm(W) x 30mm(H) pick-to-light module	<ul style="list-style-type: none"> • 3-digit display / Display com 3 dígitos / Display a 3 cifre / Pantalla de 3 dígitos / Affichage 3 chiffres 	
PTL702		100mm(L) x 46mm(W) x 30mm(H) pick-to-light module	<ul style="list-style-type: none"> • 2-digit display / Display com 2 dígitos / Display a 2 cifre / Pantalla de 2 dígitos / Affichage 2 chiffres • 2 up/down function keys / 2 teclas de função para cima / baixo / 2 tasti di funzione alto / basso / 2 arriba / abajo teclas de función / 2 touches de fonction haut / bas 	











Pick-to-Light – Modules

| Pick-to-Light - Módulos | Pick-to-Light – moduli | Pick-to-Light – Módulos | Pick-to-Light - Modules

Série
PTL7XXX

Power requirements: DC12V, Max: 100mA



Pick-to-Light – Modules				
Pick-to-Light – Módulos / Pick-to-Light – Moduli / Pick-to-Light – Módulos / Pick-to-Light – Modules				
Reference Referência Artículo Referencia Référence	Product Produto/ Prodotto Producto / Produit	Description Descrição/Descrizione Description/Description	Characteristics Características / Caratteristiche / Características / Caracteristiques	Colours Cores/Colore Colores/Couleur
PTL706		148mm(L) x 46mm(W) x 30mm(H) pick-to-light module	•6 digit order display / Display com 6 dígitos / Display a 6 cifre / Pantalla de 6 dígitos / Affichage 6 chiffres	
PTL70C		260mm(L) x 46mm(W) x 30mm(H) pick-to-light module	•12-digit alphanumeric display / Display com 12 dígitos / Display a 12 cifre / Pantalla de 12 dígitos / Affichage 12 chiffres •1 confirmation button + 2 function keys / 1 botão de confirmação + 2 teclas de função / 1 tasto di conferma + 2 tasti funzione / 1 botón de confirmación + 2 teclas de función / 1 bouton de confirmation + 2 touches de fonction •LED indicator + buzzer / Indicador LED + campainha / Indicatore LED + campanello / Indicador LED + zumbador / Indicateur LED + ronfleur	
PTL710M		148mm(L) x 46mm(W) x 30mm(H) pick-to-light module	•Melody Completion / Melodia de conclusão / Melodia di completamento / Melodia finalización / Mélodie achèvement •Confirm button / Botão confirmar / Pulsante conferma / Botón confirmar / Bouton confirmer •Green LED light + speaker / Luz LED verde + altifalante / LED verde luce + altoparlanti / La luz LED verde + altavoz / LED Feu vert + haut-parleur	
PTL712		74mm(L) x 46mm(W) x 30mm(H)	•DI/DO Interface / DI / DO interface / DI / DO interfaccia / DI / DO Interfaz / DI / DO Interface	
PTL730		148mm(L) x 46mm(W) x 30mm(H) - RS232 Converter	•1 LED signal indicator / 1 indicador de sinal LED / 1 indicatore del segnale LED / 1 Indicador de señal LED / 1 LED de signalisation	
PTL70N		74mm(L) x 46mm(W) x 30mm(H) pick-to-light module	•Power requirements:DC12V,Max:100mA	Confirmation button colour
PTL706-24-3K		200mm(L) x 46mm(W) x 30mm(H) - 6-Digit, 2 Color Display Pick Tag	•2 up/down function keys + 1 function key / 2 teclas de função para cima / baixo + 1 tecla de função / 2 tasti funzione up / down + 1 tasto Funzione / 2 teclas de función arriba / abajo + 1 tecla de función / 2 haut / bas touches de fonction + touche 1 de fonction	
PLT705-RFID		200mm(L) x 46mm(W) x 30mm(H) - 6-Digit, 3 Separated Windows Pick Tag	•5-digit display / Display com 5 dígitos / Display a 5 cifre / Pantalla de 5 dígitos / Affichage 5 chiffres •RFID reader / Leitor de RFID / Lettore RFID / Lector RFID / Lecteur RFID •2 up/down function keys + one function key / 2 tasti funzione up / down + 1 tasto Funzione / 2 teclas de función arriba / abajo + 1 tecla de función / 2 haut / bas touches de fonction + touche 1 de fonction	
PTL706-3W-123-3K		200mm(L) x 46mm(W) x 30mm(H) - 6-Digit, 3 Separated Windows Pick Tag	•6-digit, 3 separated windows display / Display com 6 dígitos, 3 janelas separadas / Display a 6 cifre, 3 vetrine separate / Pantalla de 6 dígitos, 3 ventanas separadas / Affichage 6 chiffres, 3 vetrine separate •1 confirmation button + 3 function keys / 1 botão de confirmação + 3 teclas de função / 1 tasto di conferma + 3 tasti funzione / 1 botón de confirmación + 3 teclas de función / 1 bouton de confirmation + 3 touches de fonction	

Pick-to-Light – Wireless

| Pick-to-Light – Sem fios | Pick-to-Light – Senza fili | Pick-to-Light – Sin hilos | Pick-to-Light - Sans fil

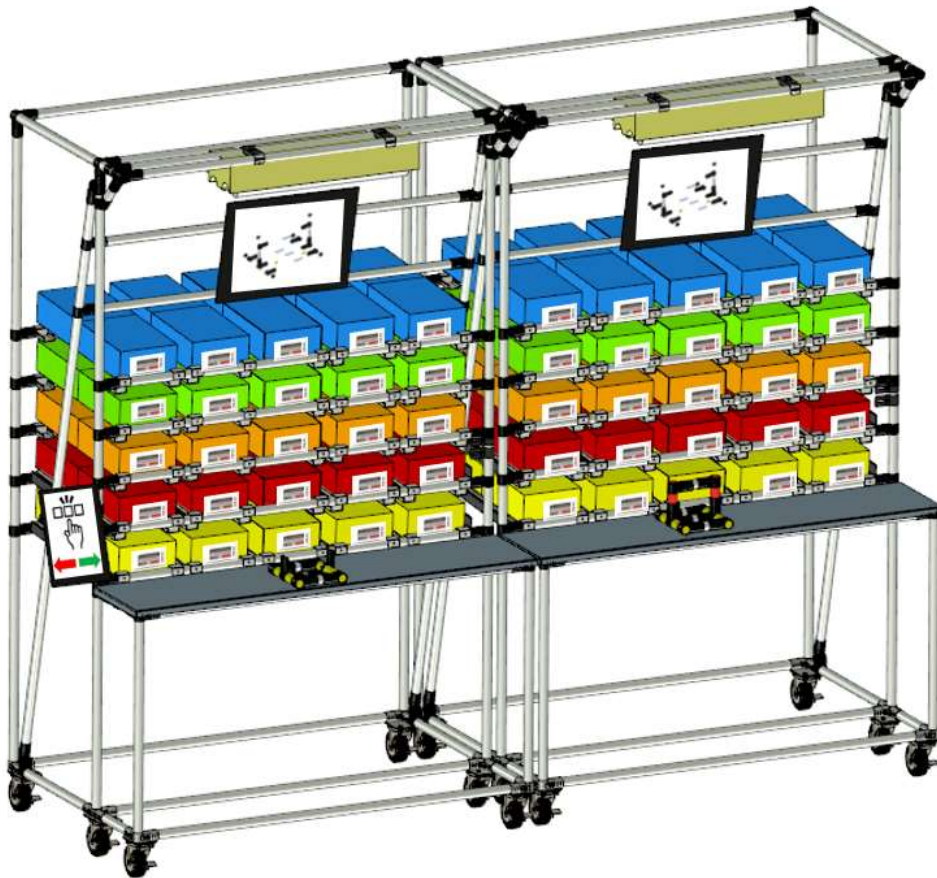



Pick-to-Light – Kit		
Pick-to-Light –Kit/ Pick-to-Light –Kit / Pick-to-Light – Kit / Pick-to-Light - Kit		
Reference Referência Articolo Referencia Référence	Product Produto/ Prodotto / Producto / Produit	Accessories included Acessórios incluídos/ accessori inclusi/ accesorios incluidos/accessoires inclus
PICK-KIT		<p>Hardware infrastructure:</p> <ul style="list-style-type: none"> 1 PC Management System Electronic Labels 1 Access Point 868 Mhz 1 Router to create the internal connection network between PC and Access Point 50 Graphic Labels 2.2" - black / white 50 Base plates for coupling <p>Software:</p> <ul style="list-style-type: none"> Software License Ses-Imagotag OM-Link license Does not include Tablet for operation management and Monitor / TV 32"

Andon System

| Sistema Andon| Andon di sistema| Sistema Andon | Système Andon

CUSTOMIZED SOLUTION

Andon System			
Sistema Andon Andon di sistema Sistema Andon Système Andon			
Product Prodotto Producto Produit	Nº of signals Nº de Sinais Nº di segnali Nº de señales Nº de de signaux	Characteristics Características Caratteristiche Características Caracteristiques	Image Imagem Immagine Foto Image
Lights Luz Luce Ligera Lumière	1	Customizable colors sequence Sequência de cores personalizavel Sequenza di colori personalizzabile Secuencia de colores personalizables Séquence de couleurs personnalisable	
	2		
	3		
	4		
	5		
	6		
light switch Interruptor Interruttore della luce Interruptor de luz Interrupteur		Independent switch for each Led Interruptores independentes Interruttore indipendente per ciascun Led Interruptor independiente para cada led Interrupteur indépendant pour chaque Led 220V Plug Ficha 220V Spina 220V Enchufe 220V Prise 220V	
Light Support Suporte da Luz Supporto Soporte Support		Customizable Personalizavel Personalizzabile Personalizable Personnalisable	



Digital Andon System

| Sistema Andon Digital | Andon digital sistema | Sistema Andon Digital | Système Andon

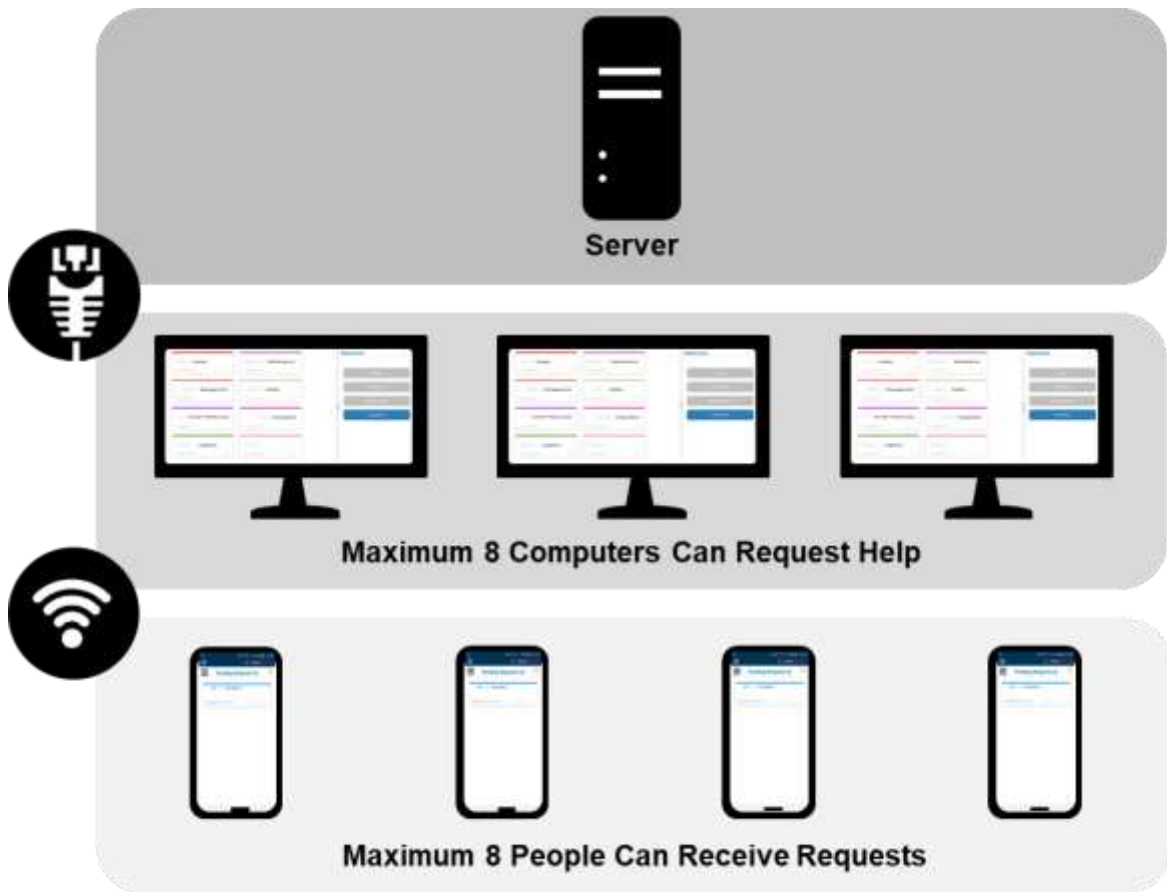

- Web based ✓
- Multilingual ✓
- Usable on Touch Screens ✓
- Usable on Android Smart Phone ✓



4 LEAN

4.0 Lean

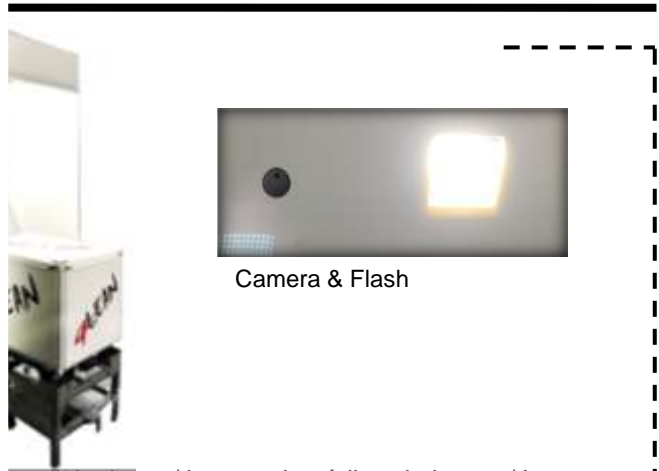
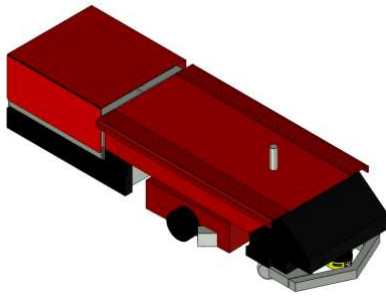

Camera & Flash

codici a barre/ lectura de código de barras/ Lecture

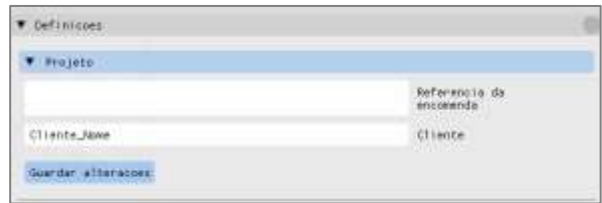

Vol. VI

We Build Lean

For details or big items



Organize photos

organizar as fotos/ organizzare le foto/ organizar fotos/ organiser des photos

Fast Search

Nome	Customer reference	Date	Time	Camera
1902214004046_2017_01_04_10_08_30_0013_229_235_cam02.jpg	1902214004046	2017_01_04	10_08_30	0013_229_235_cam02
1902214004046_2017_01_05_10_40_50_0183_230_235_cam02.jpg	1902214004046	2017_01_05	10_40_50	0183_230_235_cam02
1902214004046_2017_01_05_10_40_57_0197_231_235_cam02.jpg	1902214004046	2017_01_05	10_40_57	0197_231_235_cam02
1902214004047_2017_01_03_17_27_01_0480_225_231_cam02.jpg	1902214004047	2017_01_03	17_27_01	0480_225_231_cam02
1902214004047_2017_01_03_17_27_13_0048_226_232_cam02.jpg	1902214004047	2017_01_03	17_27_13	0048_226_232_cam02
1902214004047_2017_01_03_17_27_27_0655_227_233_cam02.jpg	1902214004047	2017_01_03	17_27_27	0655_227_233_cam02

Watch the video



Save data in the server automatically



Save & Control

Azitec - Milk Run Tracking System

| Sistema de rastreamento Milk Run | Sistema di monitoraggio della corsa Milk Run | Sistema Seguimiento Milk Run | Système de suivi de la Milk Run

Milk run tracking system

- Supervise el rendimiento de los trens logísticos en instalaciones industriales. Aprovechando los datos en tiempo real, prediga rutas y estime la hora de llegada a cada estación. Transforma los datos recopilados en análisis detallados, como el tiempo promedio de espera y de viaje en cada punto de control, la identificación de atascos o el rendimiento de la ruta
- Monitor the performance of tow tractors in industrial facilities. By leveraging real-time data, predict routes and estimate the time of arrival at every station. Transforms the collected data into insightful analytics such as average waiting and traveling time in each checkpoint, bottleneck identification or route performance
- Monitorizar o desempenho de comboios logísticos em instalações industriais. Aproveitando os dados em tempo real, preveja rotas e estime a hora de chegada em cada estação. Transforma os dados coletados em análises perspicazes, como tempo médio de espera e viagem em cada ponto de verificação, identificação de gargalos ou desempenho da rota



Azitec - Asset Management System

| Sistema de gestão de ativos | Sistema di gestione patrimoniale | Sistema de gestión de activos | Système de gestion des actifs

Asset Management system

- Permite a las empresas ganar visibilidad y administrar mejor sus activos. Al adjuntar etiquetas de bajo costo a cada activo, las organizaciones pueden rastrear el estado del inventario, la ubicación y supervisar las cadenas de suministro circulares en tiempo real
- Enables companies to gain visibility and better manage of their assets. By attaching low-cost active tags to every asset, organizations can track the inventory status, location, and oversee circular supply chains in real-time
- Permite que as empresas ganhem visibilidade e giram melhor os seus ativos. Ao anexar tags de baixo custo a cada ativo, as organizações podem rastrear o status do inventário, a localização e supervisionar as cadeias de abastecimento circulares em tempo real

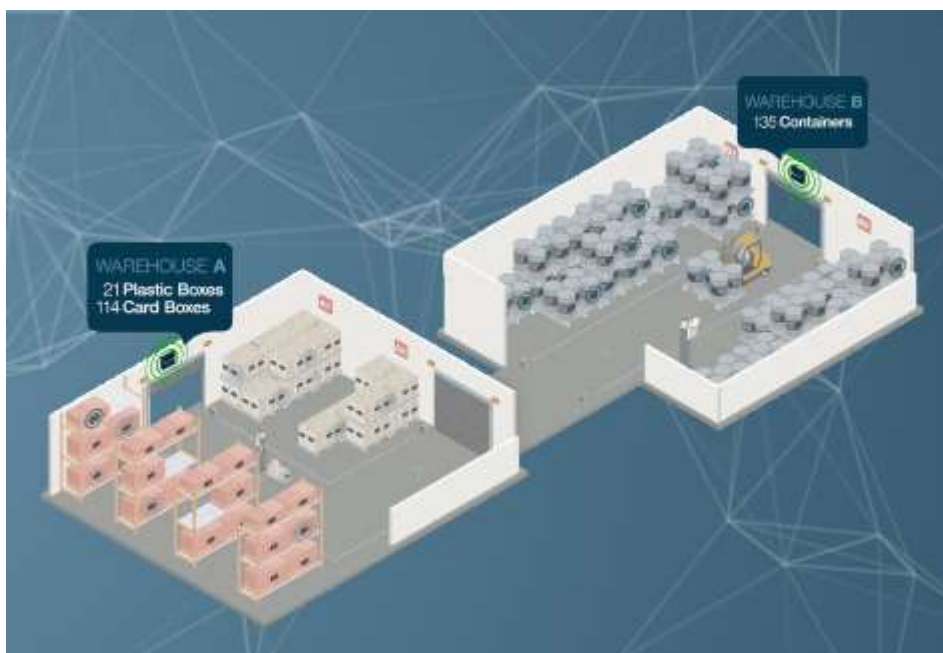

XMach

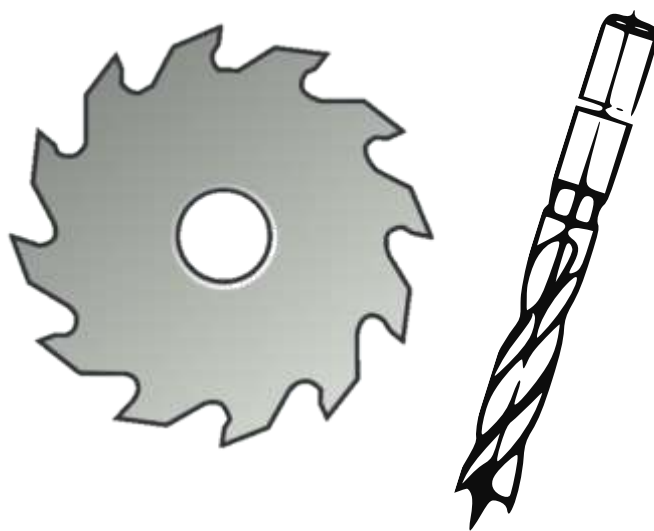

Smart Machines

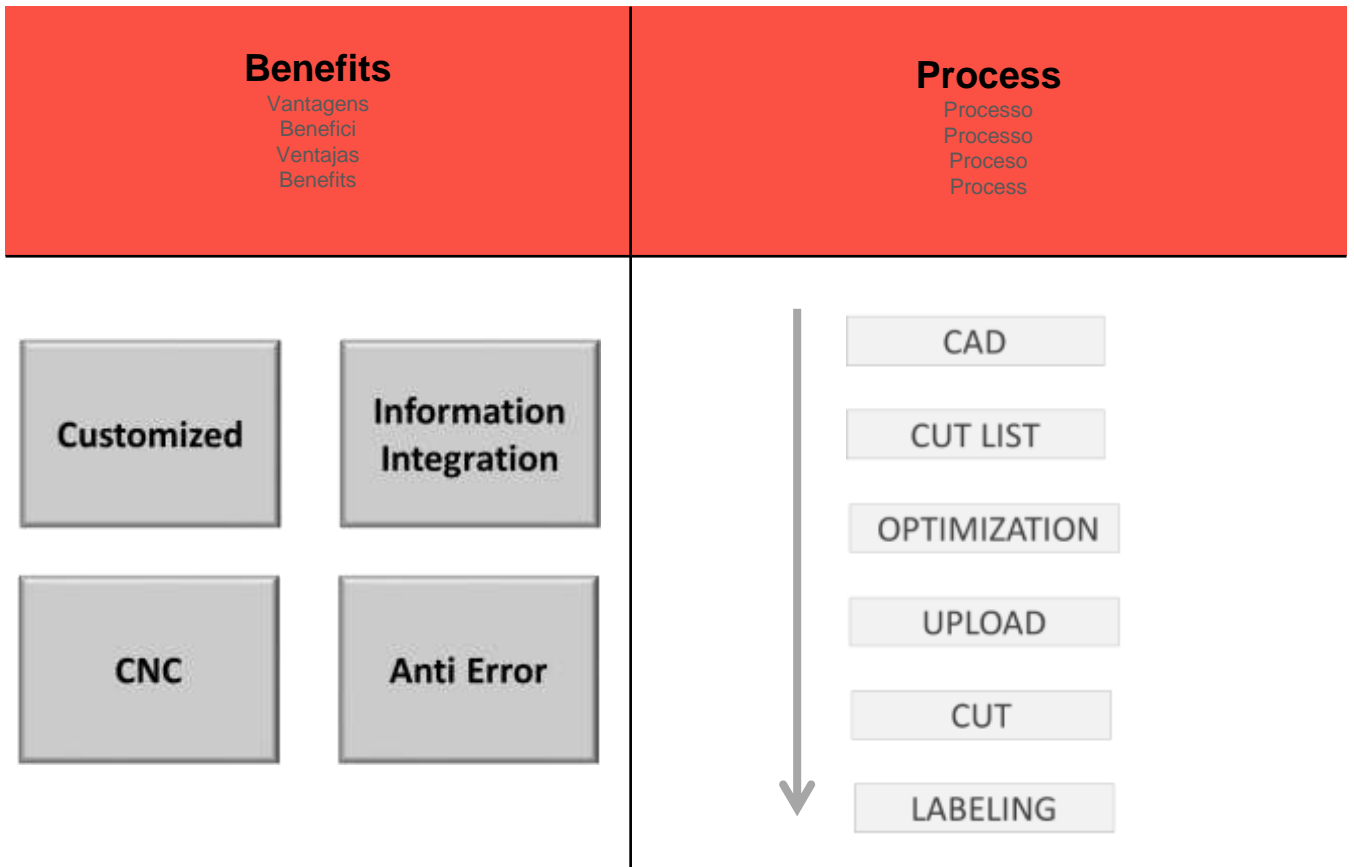

Smart Machines

Máquinas feitas á medida| Macchine su misura| Máquinas a medida| Custom made machines



Product Produto/ Prodotto/ Producto/ Product	
<p style="text-align: center;">Drill Machine</p> <p style="text-align: center;">Engenho de furar/Dispositivo di perforazione/ Dispositivo de perforación/Drill Machine</p>	<p style="text-align: center;">Saw Machine</p> <p style="text-align: center;">Máquina de serra /Macchina per sega/ Máquina de Sierra/ Saw machine</p>
	

Custom Made Machines

Máquinas feitas á medida | Macchine su misura | Máquinas a medida | Custom made machines

CUSTOMIZED
SOLUTION

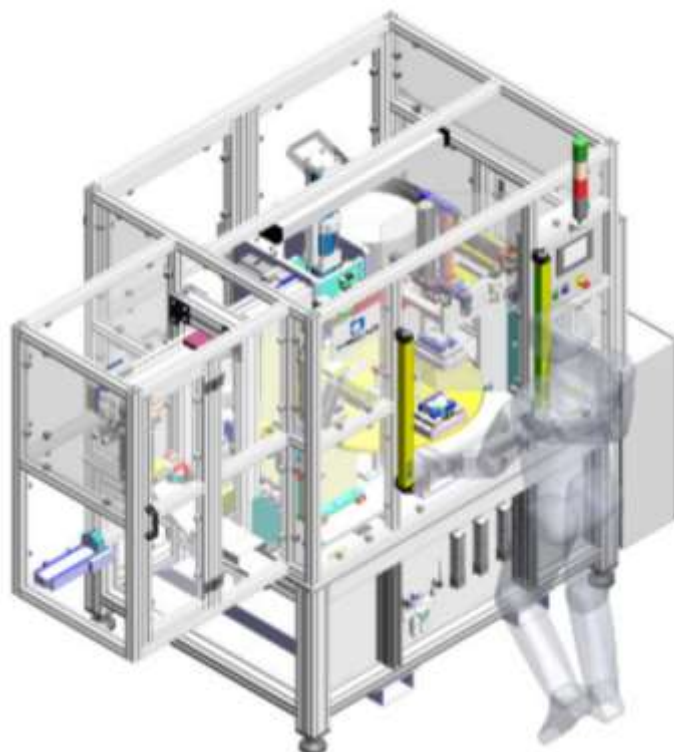
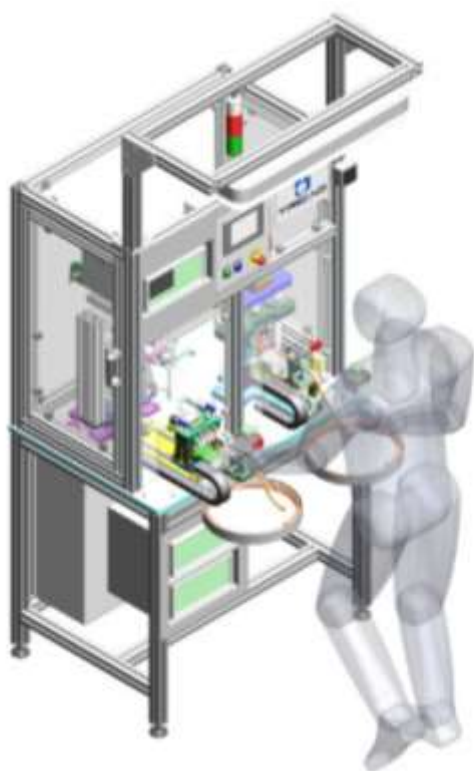

UK **4LEAN**

DE **4LEAN**

Iberia **4LEAN**

4LEAN

Italy **4LEAN**



Liverpool

Stuttgart

Bergamo

Porto

Bilbao

Some of our clients

| Alguns dos nossos clientes | Alcuni dei nostri clienti | Algunos de nuestros clientes |
Certains de nos clients

Horeca Equipments



Industrial and Agricultural Vehicles



Power transmission



Automotive



Aeronautics



Small Appliance



E-Commerce & Warehouse



Elevators



We Build Lean

4Lean, Lda
4lean@4lean.net
www.4lean.net

Some of our clients

| Alguns dos nossos clientes | Alcuni dei nostri clienti | Algunos de nuestros clientes |
Certains de nos clients

White goods

POLIDORO
by arredo3

sisme

METEOR
by arredo3

Whirlpool

Electrolux

FABER

Bicycles

SRAM

Maias

Micanda
The European Bike Fundamentals

rte

ALUBIKE

Campagnolo

LOMBARDO
CC SRM

ORBEA

Electrical

ABB

CAME

bticino

efacec

OSRAM

WESTRAFO

EFAPEL

SIEMENS

simon

Electronics

ALFA
ELECTRONICS

TE
CARDIOLINE

flex

KEMET
a YAGEO company

CAREL

OLYMPUS

vision-box

VISHAY

ES
ELECTRONICS

Fashion

LVMH
LUXURY MODERNIZATION

NIKE

YSL

YKK

SWATCH GROUP

BALLY

KERING

Process Industry

Nestlé

BANCO DE PORTUGAL
SOPORTE

NAVIGATOR
LOGISTICS

Coca-Cola

thyssenkrupp

PESCANOVA

Tetra Pak

Recipharm
good for business

Ventilation and refrigeration

VERTIV.

Parker

Swegon

EBT

kide

TROX[®] TECHNIK
The art of handling air

arneg

Keyter

WoodWorking

IKEA

ALF

BRUGNOTTO
GROUP

PIANCA

Arredo3

ernestomeda

TECNOFORM

Valcucine

Industrial Machines

+GF+
GEORG FISCHER

GEA
TECHNICAL GROUP

magic
MAGN APPLICAZIONI

BOBST

salvagnini

MEGA

FRIUL
INTAGLI

WAGNER

We Build Lean

4Lean, Lda
4lean@4lean.net
www.4lean.net

Some of our clients

| Alguns dos nossos clientes | Alcuni dei nostri clienti | Algunos de nuestros clientes |
Certains de nos clients

Services



Healthcare



Construction Components



Coachworks



HandTools



Public Sector



We Build Lean

4Lean, Lda
4lean@4lean.net
www.4lean.net